

COMPACT L-BLOCK WITH DOSE CALIBRATOR SHIELD

Space-saving design – Ideal for mobile units



- 1.5" thick lead shielding in front, 1" in base
- 8" x 8" x 4" adjustable lead glass window
- 1" thick lead shield surrounds calibration chamber
- Optional Lead Brick Cave for complete lateral shielding

The unique Compact L-Block with Dose Calibrator Shield is designed to maximize space in facilities receiving and preparing doses of high-energy nuclides such as FDG F-18. This unit provides convenient access and viewing of the work area and incorporates a built-in calibration chamber shield. The special shield is designed to accommodate a chamber that is through-mounted in a countertop (customer responsible for installation). The chamber shield accommodates all Atomlab chambers and many others (check chamber shield specifications to determine fit). This combination of L-Block and dose calibrator shield eliminates the need to purchase interlocking shielding rings. This unit is constructed of lead encased in steel. It features a large 8" x 8" x 4" lead glass window with adjustable window angle, 1.5" thickness lead shielding in front, and 1" thick lead in the base and in the chamber shield. A special plate with a hex-shaped recess is mounted on the L-Block base to facilitate one-handed loading and unloading of dose pigs incorporating hex-shaped bottoms. The optional 042-434 Lead Brick Cave fits neatly into the sides of the vertical section to provide lateral shielding around the full perimeter of the L-Block's base. For hot labs in mobile vans, the optional Brick Cave Cover will prevent the cave from shifting when the vehicle is in motion.

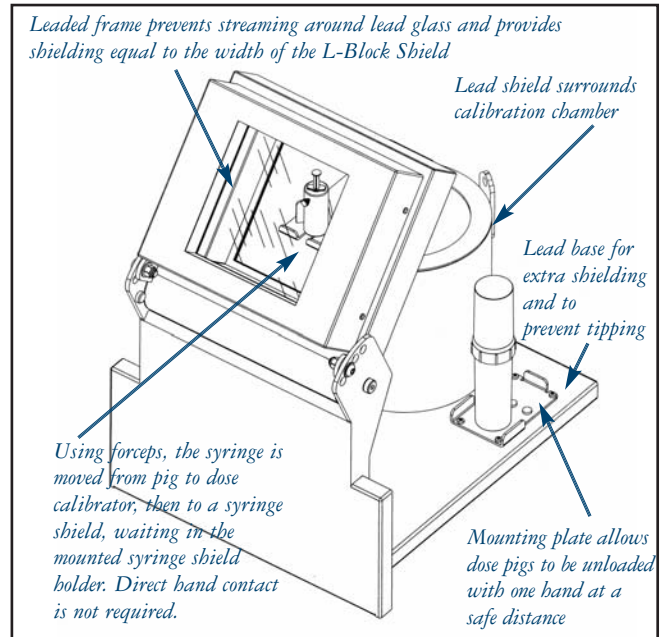

SPECIFICATIONS:

042-433 Compact L-Block with Dose Calibrator Shield

Dimensions: 18" w x 21.5" depth x 26" h (45.7 x 54.6 x 66 cm)

Lead Shielding:

Front: 1.5" thick (3.8 cm)

Base: 1" thick (2.5 cm)

Calibrator Shield: 1" thick (2.5 cm)

Calibrator Shield Inside Dimensions: 6.85" I.D. x 10.25" h (17.4 x 26 cm)

Lead Glass Window:

Dimensions: 8" w x 8" h x 4" thick (20.3 x 20.3 x 10.2 cm)

Density: 5.2 g/cm³

Finish: Powder coat

Weight: 570 lb (259 kg)

Shipping Weight: 590 lb (267.6 kg)

042-434 Interlocking Lead Brick Cave

Dimensions:

I.D.: 14" w x 20.5" depth x 16" h (35 x 52.1 x 40.6 cm)

Lead Shielding: 2" thick (5 cm)

Finish: Paint

Weight: 597 lb (271 kg)

042-433 Compact L-Block with
Dose Calibrator Shield, 1.5" lead
With built-in Dose Calibrator Shield

Related:

042-434 Lead Brick Cave, 3-wall, 2" lead
Fits 042-433 L-Block Shield

042-435 Lead Brick Cave Cover
Fits 042-434 Lead Brick Cave

Biodex L-Block Shields incorporate a hex-shaped plate to facilitate one-handed loading and unloading of Biodex PET Pigs.

This product is available through:

JRT Associates 800-221-0111